

Owner's Maintenance & Service Manual



Modern Trailer Pty Ltd



MODERN TRAILERS

Thank You

From Modern Trailers

Dear Customer,

Welcome to Modern Trailers,

A company dedicated to providing the right product for people on the move.

Modern Trailers are a skilled Australian trailer manufacturer with a commitment to quality service & value for money that can build the trailer that is right for you.

At Modern Trailers we are dedicated to building our reputation as one of the most accomplished trailer manufacturers in Adelaide, South Australia, and across all of Australia. Our trailers are innovatively designed, very practical, and made to rigorous manufacturing standards. The Trailer Range section list the diverse types of trailers we have available and useful information on what they can do for you.

If you need some advice, then you can contact at sales@moderntrailers.com.au

Please let Modern Trailers know how we can be of service now and in the future.

Thank again for choosing Modern Trailers. . .

Trailer & Customers Details

V.I.N. Number																			
----------------------	--	--	--	--	--	--	--	--	--	--	--	--	--	--	--	--	--	--	--

Reg No		DEALER	
--------	--	--------	--

MONTH/ YEAR MANUFACTURE		MODEL	
COLOUR		DELIVERY DATE	

Owner Details

Company Name			
First Name		Surname	
Adress			
		Post Code	
Postal Adress			
		Post Code	
Email Adress			
Telethone	B/H		Mobile

⚠️ WARNING

This user's manual contains safety information and instructions for your trailer.

You must read this manual before loading or towing your trailer.

You must follow all safety precautions and instructions.

Contents

1 SAFETY INFORMATION	1
1.1. Safety Alert Symbols and Signal words	1
1.2. Major Hazards	2
1.2.1. Improper sizing of the trailer to the tow vehicle.....	2
1.2.2. Driving Too Fast	2
1.2.3. Failure to adjust driving behaviour when towing a trailer.....	3
1.2.4. Improper Loading.....	3
1.2.5. Trailer not Properly coupled to the towing Vehicle	4
1.2.6. Proper use of safety chains.....	4
1.2.7. Proper connection of Breakaway brake	5
1.2.8. Matching Trailer coupling and ball.....	6
1.2.9. Worn Tires, Loose wheel Nuts.....	6
1.2.10. Weight and Load Distribution.....	8
1.2.11. Shifting Cargo	9
1.2.12. Inoperable Brakes or lights.....	9
1.2.13. Hazards from Operations a Hydraulic Tipper Trailer	10
1.2.14. Hazards from Modifying Your Trailer	12
1.2.15. Trailer Towing Guide	12
1.2.16. Safe Trailer Towing Guidelines	13
2 COUPLING TO THE TOW VEHICAL.....	14
2.1. Use an adequate tow vehicle	14
2.2. Trailer information (VIN)	14
2.3. Tow Vehicle	15
2.4. Coupling and uncoupling the trailer	15
2.5. Before coupling the trailer to the tow vehicle	17
2.6. Connecting the Safety Chains	18
2.7. Connecting the Electrical Cable	19
2.8. Uncoupling the Trailer	19

3	LOADING THE TRAILER	20
	Tow Bar Weight	21
4	CHECKING THE TRAILER DURING & BEFORE EACH TOW	22
	4.1	Pre-Tow Check 22
	4.2. Make Regular Stops	22
	4.3. Retighten wheel nuts at 1st 50km, 1st 100km, 1st 200km and every 1000 kilometre's thereafter.....	22
5	BREAKING-IN A NEW TRAILER.....	24
	5.1 Adjust Brakes shoes	24
	5.4 Check Hubs	24
6	INSPECTION, SERVICE & MAINTANANCE	25
	6.1	Inspection, Service & Maintenance Summary Charts 25
	6.2 Bearing & Hub Service	26
7	TECHINCAL REFERNCE.....	27
	7.1 TRAILER LIGHTING ELECTRICAL CONNECTION	27
	7.2 Axle sizes & Bearing Numbers	28
	LM Bearing Sets	28
	Slimline Bearing Sets	28
	Parallel Bearing Sets	28
	7.3 Springs	29
	7.4	Slipper Springs 29
	7.5 Parts required for spring fittings are:	29
	7.6 Shackle Springs (Figure 1)	30
	7.7 Rocker Roller Springs	31
	7.8 Parts required for mounting axles to the springs are:	31
8	- Structural Warranty	32
9	- Maintenance & service scheduling:.....	34-41

1 SAFETY INFORMATION

1.1. Safety Alert Symbols and Signal words

This manual provides instructions for the operation and care of your Modern Trailer. The instructions of this manual must be followed to ensure the safety of persons and livestock, and satisfactory life of the trailer. Safety precautions to protect against injury or property damage must be followed at all times.

An owner's manual that provides general trailer information cannot cover all of the specific details necessary for the proper combination of every trailer, tow vehicle and hitch. Therefore, you must read, understand and follow the instructions given by the tow vehicle and towbar manufactures, as well as the instructions in this manual.

Our Trailers are built with components produced by various manufactures as such some items may have separate instruction manuals that must be followed.

Safety information in this manual is denoted by the safety alert symbol:



The level of risk is indicated by the following signal words.

DANGER

DANGER- Hazards which will result in severe personal injury or death if the warning is ignored.

WARNING

WARNING- hazards or unsafe practices which could result in severe personal injury or death if the warning is ignored.

CAUTION

CAUTION- hazards or unsafe practices which could result in minor or moderate injury or death if the warning is ignored.

NOTICE

CAUTION- hazards or unsafe practices which could result in minor or moderate injury or death if the warning is ignored.

Section 1 – Safety Information

1.2. Major Hazards

Loss of control of the trailer or trailer tow vehicle combination can result in death or severe injury. The most common cause of loss of control of the trailer are:

- Improper sizing the trailer for the tow vehicle, or vice versa.
- Excessive Speed: Driving too fast for the conditions.
- Failure to adjust driving behaviour when towing a trailer.
- Overloading and/or improper weight distribution.
- Improper or miss-coupling the trailer to the tow ball.
- Safety chains not attached to the tow vehicle correctly.
- Improper braking and steering under sway conditions.
- Not maintaining proper tire pressure.
- Not keeping wheel nuts to the correct torque.

1.2.1. Improper sizing of the trailer to the tow vehicle.

Trailers that weigh too much for the towing vehicle can cause stability problem, which can lead to death or severe injury. Furthermore, the additional strain put on the engine drive chain and suspension may lead to serious vehicle maintenance problems. For these reasons the maximum towing capacity of your towing vehicle, in terms of maximum gross trailer weight (ATM) and maximum gross combined weight rating (GTM) can be found in the tow vehicles owner's manual.

⚠ DANGER

Use of an under-rated Tow-bar, Ball or tow vehicle can result in loss of control leading to death or severe injury.

Make certain you tow bar and tow vehicle are rated for your trailer.

1.2.2. Driving Too Fast

With ideal road conditions the maximum recommended speed for safely towing a trailer is 110kph. If you drive too fast, the trailer is more likely to sway, thus increasing the possibility for loss of control.

⚠ WARNING

Driving too fast for conditions can result in loss of control and cause death or severe injury.

Adjust speed down when towing a trailer.

Section 1 – Safety Information

1.2.3. Failure to adjust driving behaviour when towing a trailer

When towing a trailer, you will have decreased acceleration, increased stopping distance and increased turning radius (**WHICH MEANS YOU MUST MAKE WIDER TURNS TO KEEP FROM HITTING KURBS, VEHICALS AND ANTHING ELSE THAT IS INSIDE THE CORNER**). Furthermore, the trailer will change the handling characteristics of your towing vehicle, making it more sensitive to steering inputs and more likely to be pushed around in windy conditions or when being passed by large vehicles. In addition, you will need a longer distance to pass due to slower acceleration and increased length.

With this in mind:

- Be alert for slippery conditions. You are more likely to be affected by slippery road surfaces when driving towing a trailer than driving without a trailer.
- Anticipate the trailer “swaying” Swaying can be caused by excessive steering, speed, wind gusts, improper weight distribution or by pressure wave created by passing trucks or busses.
- When encountering trailer sway, take your foot off the accelerator, and steer as little as possible to stay on the road. Use small “trim-like” steering adjustments. Do not attempt to steer out of the sway, you’ll only make it worse. Also, do not apply the tow vehicles brakes to correct the swaying. The application of the trailer brakes being applied will help straighten the trailer.
- Check rereview mirror frequently to observe the trailer and traffic.
- Use lower gear when driving down steep or long grades. Use the engine and transmission as a brake. Do not ride the brakes, as they can overheat and become ineffective.
- Be aware of your trailer height, especially when approaching bridges, roofed areas and around trees.

1.2.4. Improper Loading

The total weight of the load you put in or on the trailer, plus the empty weight of the trailer itself must not exceed the trailers Gross Trailer Mass (GTM). This information can be found on the compliance plate that is fitted on the trailer, if this plate is not fitted you must weigh it on a commercial weigh bridge. In addition, you must distribute the load in the trailer such that the load on any axle does not exceed the gross axle weight rating.

WARNING

An overloaded trailer can result in failure or loss of control of the trailer, leading to death or server injury.

Never load a trailer so that the weight on any tyre exceeds its rating.

Never exceed the trailer Gross trailer mass GTM.

Never exceed the axle load capacity.

Section 1 – Safety Information

1.2.5. Trailer not Properly coupled to the towing Vehicle

It is critical that the trailer be securely coupled to the tow vehicle and that the safety chains are and or emergency breakaway line are correctly attached by using the correct size of rated D-Shackles. Uncoupling may result in death or severe injury to you and others.

⚠ WARNING

Coupling and tow bar selection are critical for safe towing.

Uncoupling can result in death or severe injury.

- Make sure the Coupling and ball are rated for the trailer
- Make sure the ball size matches the coupling.
- Check the ball for wear, corrosion and cracks before connecting the coupling.
- Make sure the safety latch on the coupling is all the way down.

⚠ WARNING

An improperly coupled trailer can result in death or server injury

Do not move the trailer until:

- The coupling is secured and locked
- The safety chains are secured to the towing vehicle and crossed over
- The trailer Jacks or Jockey wheel are full retracted (IF FITTED)

Do not tow the trailer on the road until:

- The brakes are check (If fitted)
- The breakaway switch is connected to the tow vehicle (If Fitted)
- The load is secured
- The Trailer lights are connected and checked.

1.2.6. Proper use of safety chains

Safety chains are provided so that the trailer is still connected if the trailer comes loose from the tow vehicle for any reason.

Section 1 – Safety Information

WARNING

Incorrect connection of the safety chains can result in loss of the trailer, leading to death or server injury if the trailer uncouples from the towing vehicle.

Chain Must:

- Fasten to the frame of the tow bar
- Cross chains over underneath the tow bar with minimum slack to permit turning and to hold the draw bar up, if the trailer comes loose.

1.2.7. Proper connection of Breakaway brake

If fitted with electric brakes rated over 2000kg, your trailer will be fitted with a breakaway brake system that can apply the brakes on your trailer, if your trailer comes loose from the towing vehicle for some reason. You will have separate a separate set of instructions for the breakaway brake if your trailer is so equipped. The breakaway brake system, including the battery charge must be in good condition to be effective.

WARNING

An ineffective breakaway brake system can result in a runaway trailer, leading to death or severe injury if the coupling or ball fails.

Test the function of the breakaway brake system before towing the trailer. Do not tow the trailer if the breakaway brake system is not working: Have it serviced or repaired.

Connect the breakaway cable to the tow vehicle.

NOT to the safety chains of the trailer.

USE only rated shackles.

Section 1 – Safety Information

1.2.8. Matching Trailer coupling and ball

⚠ DANGER

Use of an underrated coupling, tow ball or tow bar can result in loss of control leading to death or server injury.

Make sure your coupling is correct attached to your towing vehicle.

1.2.9. Worn Tires, Loose wheel Nuts

Just as with your tow vehicle, the trailer tyres, and wheels are important safety items. Therefore, it is essential to inspect the trailer tires before each tow.

If a tyre has a bald spot, bulge, cut or cracks, or is showing any cords, replace the tire before towing. If a tire has uneven tread wear.

Tyres with little tread will not provide adequate friction forces on wet roadways and can result in loss of control, leading to death or server injury.

Improper tyre pressure causes increased tyre wear and may reduce trailer stability, which can result in a tyre blow out or possible loss of control. Therefore, before each tow you must also check the tyre pressures. Remember, the proper tyre pressure is listed on the VIN Plate and should be checked when tyres are cold. Allow 3 hours cool-down after driving as much as 2 kilometres before checking tyre pressures.

⚠ WARNING

Improper tyre pressure may cause an unstable trailer, Blowout and loss of control may occur. Death or serious injury can occur.

Make sure of proper tyre pressure before towing the trailer. Inflate tyres to the pressure indicated on the VIN plate label.

Section 1 – Safety Information

The tightness of the wheel nuts is very important in keeping the wheels properly seated to the hub. Before each tow, check to make sure they are tightened to the proper torque.

 WARNING
Metal creep between the wheel rim and nuts WILL CAUSE RIM TO LOSEN. Death or injury can occur if wheels come off. Tighten wheel nuts before each tow.

The proper tightening sequence and tightness (torque) for wheel nuts is listed in the inspection service & maintenance chapter of this manual. Use of a calibrated torque wrench to tighten the wheel nuts.

Wheel nuts are also prone to loosen after first being fitted. When driving a new trailer check to make sure they are tightened to the proper torque after the 1st 50 kilometres, 1st 100 kilometres, 1st 200 kilometres and every 1000 kilometres thereafter.

Failure to perform this check can result in a wheel parting from the trailer and a crash, leading to death or serious injury.

 WARNING
Wheel nuts are prone to loosen after first assembled. Death or serious injury can result. Check wheel nuts for tightness on a new trailer at the 1st 50 kilometres, 1 st 100 kilometres, 1 st 200 kilometres and every 1000 kilometres thereafter.

 WARNING
Inadequate torque on the wheel nuts can cause a wheel to part while towing. Death or serious injury can result. Make sure wheel nuts are tightened before towing the trailer.

Section 1 – Safety Information

1.2.10. Weight and Load Distribution

Proper loading of your trailer is essential for your safety. Tyre, wheels, axles, suspension or structural failure can be caused by overloading.

⚠ WARNING

An overloaded trailer can result in a failure or in loss of control of the trailer, leading to death or serious injury.

Never load a trailer so that the weight on any tyre exceeds its rating.

Never exceed the Gross Trailer Mass (GTM)

Never exceed the axle gross load capacity.

Improper front / rear load distribution can lead to poor trailer sway stability or poor tow vehicle handling. Poor trailer sway stability results from tongue weights that are too low, and poor tow vehicle stability results from tongue weights that are too high.

In figure 1-1, the second column shows the rule of thumb percentage of the total weight of the trailer, plus its cargo (gross Trailer Mass “GTM”) that should appear on the coupling of the trailer. For example, a small box trailer with loaded weight 750kg should have 6-10% of 750kg (45-75kg) on the coupling after loading, be sure to check that none of the axles are overloaded.

Coupling weight as a percentage of the loaded trailer weight	Percentage
Small Trailers	6-10% for small box trailers
Large Trailers	10-15% for larger tandem trailers

Coupling weight Chart – Figure 1-1

Uneven left or right load distribution can cause tyre, wheel, axle or structural failure. Be sure your trailer is evenly loaded on the left and right sides. Towing stability also depends on keeping the centre of gravity as low as possible.

⚠ WARNING

An improperly distributed load can result in loss of control of the trailer and can lead to death or serious injury.

Proper coupling weight is essential for stable trailer handling.

Distribute the load evenly, right and left, to avoid tyre overload.

Keeping the centre of gravity low and centred is essential to minimize the risk of a tip-over.

Section 1 – Safety Information

1.2.11. Shifting Cargo

Since the trailer “ride’ can be bumpy and rough, you must secure your cargo so that it does not move while the trailer is being towed.

 WARNING
A moving load can result in failure, or to loss of control of the trailer, and can lead to death or serious injury.
You must tie down all loads with proper size fasteners, ropes, straps, etc. to prevent the load from moving while travelling.

1.2.12. Inoperable Brakes or lights

Be sure that the brakes (if equipped) and all lights on your trailer are functioning properly before towing your trailer. Electric brakes and lights on a trailer are controlled via a connection to the tow vehicle, generally with a 7-pin electrical plug. Check the trailer taillights, brake lights and left/right blinkers by having someone in the car to operate them while you look at the trailer lights.

If your trailer has electric brakes, your tow vehicle will have an electric brake controller that sends power to the brakes. (Can also be fitted to the trailer to give power to the brakes)
Before towing the trailer on the road, you must operate the brake controller while trying to pull the trailer in order to confirm that the electric brakes operate. While towing the trailer less than 10kph, manually operate the electric brake controller in the tow vehicle cab. You should feel the operation of the trailer brake.

 WARNING
Failure to connect the tow vehicle lighting and braking to the trailer will result in inoperable lights and brakes and can lead to a collision.
Check that all the trailer lights and brakes work before each tow.

If your trailer has Override Mechanical disc or Hydraulic drum brakes fitted you can check to see if they are operating by driving at 20kph and stopping suddenly you should feel the brakes come on.

Section 1 – Safety Information

1.2.13. Hazards from Operations a Hydraulic Tipper Trailer

The major hazards from operation of a tipper trailer are:

- Overloading
- Improper weight distribution; both side to side and front to back
- Getting under a raised body
- Not using or improperly using of safety prop
- Modifying or altering hydraulic components
- Not dumping from a solid and level surface
- Not fully opening or removing the rear Door/Tailgate
- Jerking the trailer or hydraulics to loosen the load
- Trailer coming near or contacting power lines when body is raised
- Tipping with the trailer connected to the tow vehicle

The tow vehicle and trailer **MUST** be on a firm and level surface before raising the body. Raising the body while either the tow vehicle and/or trailer are on a soft or uneven surface may result in the tow vehicle and trailer overturning.

WARNING

A soft and/or uneven surface may result in the tow vehicle and trailer tipping over when the body is raised.

Raise the body **ONLY** if the tow vehicle and trailer are both on a firm and level surface.

WARNING

An overloaded trailer or improperly distributed load can result in death or serious injury.

An overloaded trailer can cause the hydraulic system to malfunction, resulting in the tipper body failing.

A load that is improperly distributed in the trailer can result in the trailer tipping over when the body is raised.

NEVER use an auxiliary device to help the hydraulic system raise the body.

Do not alter or substitute any hydraulic components on the trailer. The hydraulic system is designed with each component being compatible with the safe and reliable operation of the hydraulic system.

Section 1 – Safety Information

⚠ DANGER

NEVER alter or substitute any hydraulic system component. Death or serious injury may result.

An altered or component substituted hydraulic system may malfunction, resulting in the body falling without warning.

NEVER alter or substitute any hydraulic system component.

Verify that there are no overhead power lines near the trailer before raising the body. You can be electrocuted if the trailer comes near or contacts a power line.

⚠ WARNING

Risk of electrocution.

Tipper body coming near or contacting power lines may result in electrocution. Electrocution can occur without contact.

Be sure there are no overhead power lines over or near the trailer before raising the body.

The raised body **MUST** be supported by the body safety props before entering the area under the body for any reason. Empty the dump body before using safety props.

⚠ DANGER

Risk of death or serious injury

NEVER support a loaded tipper body by the safety prop.

Empty the load before using a safety prop.

NEVER enter the area under the tipper body unless the empty body is supported by a safety prop.

Section 1 – Safety Information

WARNING

Risk of death by crushing.

Tipper body can drop unexpectedly.

NEVER go under a raised body.

Use a safety prop for maintenance.

1.2.14. Hazards from Modifying Your Trailer

Essential safety items and structural integrity can be damaged by altering your trailer.

Before making any alteration to your trailer, contact Modern Trailers Pty Ltd. On 08 8326 5041 or 08 8262 2562 and describe the alteration you are contemplating. Alteration of the trailer structure or modification of mechanical, electrical, hydraulic or other systems on your trailer must be performed only by qualified technicians who are familiar with the system installed on your trailer.

NOTE: *Mudflaps are fitted by on your trailer in accordance with (ADR) Australian Standards, by removing them you are not complying with the Australian road safety rules and you also may void your warranty.*

1.2.15. Trailer Towing Guide

Driving a vehicle with a trailer in tow is very different from driving the same vehicle without a trailer in tow. Acceleration, manoeuvrability and braking are all diminished with a trailer in tow. It takes longer to get up to speed, you need more room to turn and pass, and more distance to stop when towing a trailer. You will need to spend time adjusting to the different feel and manoeuvrability of the tow vehicle with a loaded trailer. Because of the significant differences in all aspects of manoeuvrability when towing a trailer, the hazards and risks of injury are also much greater than when driving without a trailer. You are responsible for keeping your vehicle and trailer in control, and for all the damage that is caused if you lose control of your vehicle and trailer.

As you did when learning to drive an automobile, find an undeveloped area with little or no traffic for your first practice trailering. Of course, before you start towing the trailer, you must follow all the instructions for inspection, testing, loading and coupling. Also, before you start towing, adjust the mirrors so you can see the trailer as well as the area to the rear of it.

Drive slowly at first, 10 KPH or so, and turn the wheel to get the feel of how the tow vehicle and trailer combination responds. Next, make some right and left-hand turns. Watch in your side mirrors to see how the trailer follows the tow vehicle. Turning with a trailer attached requires more room.

Section 1 – Safety Information

Stop the vehicle a few times from speeds no greater than 15 KPH. If your trailer is equipped with brakes, try using different combinations of trailer/electric brake and tow vehicle brake. Note the effect that the trailer brakes have when they are the only brakes used. When properly adjusted, the trailer brakes will come on just before the tow vehicle brakes.

It will take practice to learn how to back up a tow vehicle with a trailer attached. Take it slow. Before backing up, get out of the tow vehicle and look behind the trailer to make sure that there are no obstacles. Some drivers place their hands at the bottom of the steering wheel, and while the tow vehicle is in reverse, “think” of the hands as being on the top of the wheel. When the hands move to the right (counter-clockwise, as you would do to turn the tow vehicle to the left when moving forward), the rear of the trailer moves to the right. Conversely, rotating the steering wheel clockwise with your hands at the bottom of the wheel will move the rear of the trailer to the left, while backing up. To straighten the vehicle, either pull forward, or turn the steering wheel in the opposite direction.

1.2.16. Safe Trailer Towing Guidelines

- Re-check the load tie downs to make sure the load will not shift during towing.
- Before towing check the coupling, safety chains, hand brake, tyres, wheels and lights.
- Check the wheel nuts for tightness.
- If fitted with electric brakes, adjust the brake controller to engage the trailer brakes before the tow vehicle brakes.
- Use your mirrors to verify that you have to change lanes.
- Use your indicators well in advance.
- Allow plenty of stopping distance
- Do not drive so fast that the trailer begins to sway due to speed. Never drive faster than 110kph.
- Allow plenty of room for passing. A rule of thumb is that the passing distance with the trailer is 4 times the passing distance without the trailer.
- Use lower gears for climbing and descending grades.
- Do not ride the brakes while descending grades, they may get so hot that they stop working.
- Do not brake while in a curve unless it is necessary, instead slow down before the curve and power through the curve, this way the towing vehicle remains in charge.
- Do not apply the brakes to correct extreme trailer swaying.
- Make regular stops, about once each hour to confirm that:
 - The coupling is secured to the ball and is locked over
 - Electrical connections are made
 - There is enough slack on the safety chains
 - The tyres are not visibly low on pressure
 - The load is all secure
- Inspect spring and axle bolts also U-bolts for any movement or loosening.

2 COUPLING TO THE TOW VEHICAL

This manual provides instructions for the operation and care of a Modern Trailer. The instructions in this manual must be followed to ensure safety and satisfactory life of the trailer. Safety precautions to protect against injury or property damage must be followed.

This section of the manual is organized into the following subsections:

- Using an adequate tow vehicle
- Trailer Information (VIN)
- Coupling the trailer to the tow vehicle
- Loading the trailer
- Checking the trailer for safety before each tow
- Synchronising the brakes
- Uncoupling the trailer

2.1. Use an adequate tow vehicle

If you have a tow vehicle, know your vehicle tow rating and make certain the trailer's rated capacity is less than or equal to the towing vehicle's rated towing capacity.

2.2. Trailer information (VIN)

The trailer VIN plate and compliance plate located on the Draw bar left hand side, as in figure 1.

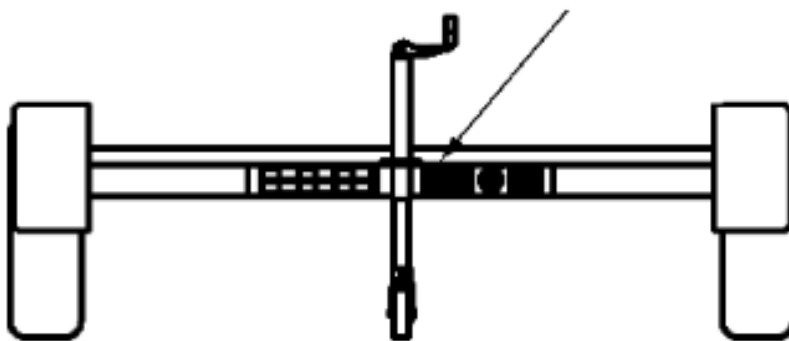

Figure 1

Section 2 - Coupling to The Tow Vehicle

The trailer compliance plate contains the following information.

- **Manufacture:** Name of the manufacture
- **Trailer Mode:** Type of Trailer
- **Date of Manufacture:** (Day/Month/Year)
- **ATM:** Aggregate Trailer Mass
- **VIN:** Vehicle Identification Number
- **RIM DETAILS:** Rim size
- **TYRE DETAILS:** Tyres sizes 18575lt etc:
- **TARE: (GTM)**Weight of the empty trailer
- **TYRE PRESURE:** 50 PS1= 345 KPA
- **ALT:** Axle Load capacity
- **SPEED:** Maximum towing speed

2.3. Tow Vehicle

When purchasing a new or second-hand vehicle to tow your trailer, ask the vehicle dealer for advice on how to outfit the towing vehicle. Discuss the following information with the dealer.

Overall carrying and towing capacity of the vehicle: Vehicle manufactures will provide you with the maximum towing capacities of their models.

Towing Hitch: The tow bar attached to your tow vehicle must have a capacity equal or greater than the load rating of the trailer you intend to tow. The Tow bar capacity must also be matched to the tow vehicles capacity.

Brake Controller: The brake controller is part of the tow vehicle and is essential in the operation of the electric brakes on the trailer (if installed). If your trailer has electric it requires a brake controller be installed at the driver's position. The brake controller is not the same as the safety breakaway brake system that is installed on the trailer if over 2000kg rated.

2.4. Coupling and uncoupling the trailer

A secure coupling of the trailer to the vehicle is essential. A loss of coupling may result in death or serious injury. Therefore, you must understand and follow all of the instructions for coupling.

Section 2 - Coupling to The Tow Vehicle

The following parts are involved in making a secure coupling between the trailer and tow vehicle.

Coupling: That part of the trailer connecting mechanism by which the connection is made to the tow bar.

Tow Bar & Tongue: That part of the trailer connecting including the ball support (Tongue) That extends and are attached to the tow bar of the towing vehicle.

Safety Chains: Safety chains are permanently attached to the trailer such that if the coupler connection comes loose, the safety chains can keep the trailer attached to the tow vehicle. With properly fitted safety chains, it is possible to keep the draw bar of the trailer digging into the road pavement, even if the coupling to the ball connection comes apart.

Criss cross the safety cross as in the figure below and be sure to use the correct rated shackles.

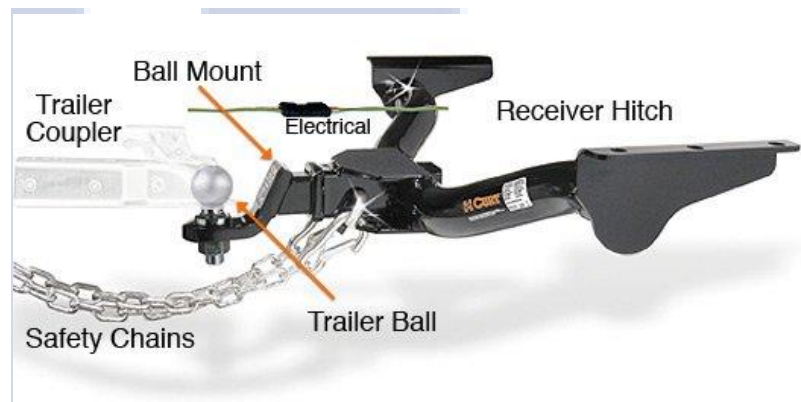
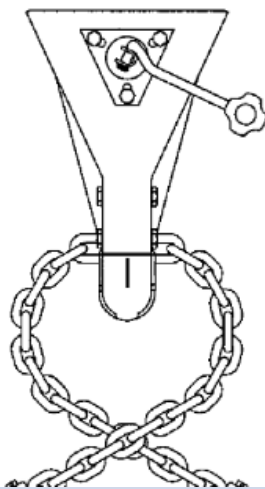

! WARNING

Incorrect connection of the safety chains can result in loss of control of the trailer and tow vehicle, leading to death and or serious injury, if the trailer uncouples from the tow vehicle.

Chains Must:

- Fasten to the tow vehicle with rated shackles
- Cross underneath coupling and tow bar lounge with minimum slack to permit turning and to hold the draw bar up, if the trailer comes apart.

Section 2 - Coupling to The Tow Vehicle

2.5. Before coupling the trailer to the tow vehicle

- Be sure the size and rating of the tow ball matches the coupling size and rating of the coupling. Balls and couplings are marked with their size and rating.

⚠ WARNING

Coupling to ball mismatch can result in uncoupling, leading to death or serious injury.

Make sure the tow bar and ball are rated for the trailer coupling.

Make sure the ball size matches the coupling.

- Wipe the ball clean and inspect it visually and by feel for flat spots, cracks or pits.

⚠ WARNING

A worn, cracked or corroded coupling or ball can fall while towing and may result in death or serious injury.

Check the coupling and ball for wear, corrosion and cracks before coupling the trailer.

Replace worn, corroded or cracked parts before connecting to the tow vehicle.

- Rock the ball to make sure it is tight to the tow bar, and visually check that the ball nut is solid against the lock washer and tow bar frame.
- Wipe the inside and outside of the coupling, clean and inspect for it visually for cracks and deformations; feel the inside of the coupling for worn spots and pits.

⚠ WARNING

A loose ball nut can result in uncoupling, leading to death or serious injury.

Make sure the ball is tight on the tow bar tongue before coupling.

- A trailer can be fitted with different types of couplings but most of them have some type of locking device either on the top or the side.

Section 2 - Coupling to The Tow Vehicle

- Open the coupling locking mechanism. Ball couplings have a locking mechanism with an internal moving piece (Ball Clamp) an outside with a latch. See figure 1 & 2
- In the open or unlatched position, the coupling is able to drop fully onto the ball. Lower the trailer coupling over the ball, then engage the locking mechanism to hold the coupling to the ball securely.
- Be sure the coupling is all the way on the ball and the locking mechanism is engaged. A properly engaged locking mechanism will allow the coupling to raise the rear of the tow vehicle.
- Using the trailer Jockey wheel or jack, test to see that you can raise the rear of the tow vehicle by 30mm after the coupling is locked to the townball.

If the coupling cannot be secured to the tow ball, do not tow the trailer.



Figure 1. 50mm coupling



Figure 2. 50mm Override Coupling

2.6. Connecting the Safety Chains

Visually inspect the safety chains and shackles for wear or damage. Replace worn or damaged safety chains before towing.

Fit the safety chains so that they are:

Criss-cross underneath the coupling so if the trailer uncouples, the safety chains can hold the draw bar up above the road. See figure 1-2

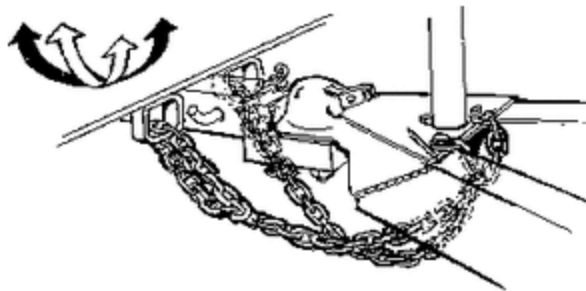

Figure-1

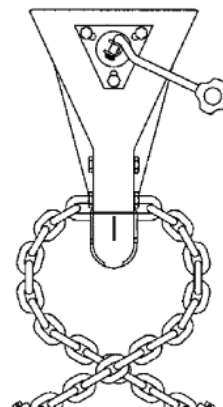

Figure-2

Section 2 - Coupling to The Tow Vehicle

2.7. Connecting the Electrical Cable

Connect the trailer lights to the tow vehicles electrical system using the electrical connector (Plug)

- Check all lights for proper operation.
- Clearance and taillights (Turn on the tow vehicles headlights).
- Brake Lights (Step on the tow vehicle brake pedal)
- Indicator signals (Operate tow vehicle directional signal lever)
- If your trailer has electric brakes, check brakes for proper operation using the brake controller mounted in the cab.

WARNING

Failure to connect the tow vehicle lighting and braking to the trailer will result in inoperable lights and brakes and can lead to a collision.

Check that all the trailer lights and brakes work before each tow.

2.8. Uncoupling the Trailer

Follow these steps to uncouple you trailer from the tow vehicle.

- Block trailer tyres to prevent the trailer from rolling, before jacking the trailer up.
- Disconnect the electrical connector
- Disconnect the safety chains from the tow vehicle
- Unlock the coupling, by pushing the locking mechanism in and lifting the coupling handle.
- Either use the jockey wheel jack or lift the coupling of the tow ball

MODERN TRAILERS

3 LOADING THE TRAILER

Improper loading causes many accidents and deaths. To safely load a trailer, you must consider:

- Overall load weight
- Load weight distribution
- Proper coupling weight
- Securing the load

To determine that you have loaded the trailer within its rating, you must consider the distribution of the weight, as well as the total weight of the trailer and its contents. The trailer axles carry most of the total weight of the trailer and its contents. GTM

The maximum weight of a trailer is specified as either its Aggregate Trailer Mass(ATM) or Gross Trailer Mass (GTM).

Aggregate Trailer Mass ATM is the combined weight of the trailer and its full load when it is not coupled to a tow vehicle.

Gross Trailer Mass (GTM) is the weight of the fully loaded trailer imposed on the trailer's axle when it is coupled to the tow vehicle

The remainder of the total weight is carried by the tow vehicle. It is essential for safe towing that the trailer draw bar, coupling and tow vehicle tow bar carry the proper amount of the loaded trailer weight, otherwise the trailer can develop an undesirable sway at towing speeds, or the rear of the towing vehicle can be overloaded. Also, the trailer draw bar can develop cracks either around the coupling or where it meets the chassis of the trailer.

The load distribution must be such that no component part of the trailer is loaded beyond its rating. This means you must consider the rating of the tyres wheels and axles. For tandem or tri-axle trailers, you must make sure that the front to rear load distribution does not result in overloading any axle.

Towing stability also depends on keeping the centre of gravity as low as possible. Load heavy items on the floor and over the axles. When loading additional items, be sure to maintain even side to side weight distribution and proper coupling weight. The total weight of the trailer and its contents must not exceed the total weight rating of the trailer.

Gross Trailer Mass (GTM)

WARNING

An overloaded trailer can result in failure or loss of control of the trailer, leading to death or serious injury.

Never load a trailer so that the weight on any tyre exceeds its rating.

Never exceed the trailer Gross Trailer Mass (GTM)

Never exceed an axle gross weight rating.

Section 3 – loading Of the Trailer

Tow Bar Weight

It is critical to have a portion of the trailer load carried by the tow vehicle. That is the trailer draw bar must exert a downward force on the tow bar. This is necessary for two reasons. First, the proper amount of coupling weight is necessary for the tow vehicle to be able to maintain control of the vehicle/trailer system. If, for example the draw bar exerts an upward pull on the tow ball, instead of pushing down on it (because the trailer is overloaded behind its axles) the rear of the tow vehicle can lose traction or grip and cause loss of control. Also, even if there is some weight on the tow ball, but not enough weight the trailer can become unstable at high speeds. Remember the faster you go the more likely the trailer is to sway.

If, on the other hand there is too much weight on the tow ball, the tow vehicle is prone to jack-knife. Furthermore, the front wheels of the tow vehicle can be too lightly loaded and cause loss of steering control and traction.

In the following table is the rule of thumb of percentage of weight on the draw bar.

Coupling weight as a percentage of the loaded trailer weight	Percentage
Small Trailers	6-10% for small box trailers
Large Trailers	10-15% for larger tandem trailers

MODERN TRAILERS

4 CHECKING THE TRAILER DURING & BEFORE EACH TOW

4.1 Pre- Tow Check

Before towing, double check all these items:

- Tyres, wheels and wheel nut tightness (torque) see chart below
- Tyre Pressure. Inflate tyres on trailer to the value indicated on the VIN plate
- Coupling secured and locked on the tow ball (see the “Coupling to Tow Vehicle” section of this manual)
- Safety chains properly attached to the tow vehicle. (see the “Coupling to Tow Vehicle” section of this manual)
- Test Tail stop and Indicators
- Cargo properly loaded, balanced and tied down. (See the “Loading of the trailer” of this manual)
- Doors and gates latched and secured

4.2. Make Regular Stops

After each 100 kilometres, or one hour if towing, stop and check the following items:

- Coupled secured
- Safety chains are fastened and not dragging
- Load secured
- Gates and doors secured
- Check tyres for signs of abnormal wear and loss of air pressure

4.3. Retighten wheel nuts at first 1st 50km, 1st 100km, 1st 200km then every 1000km's.

Wheel nuts can shift and settle quickly after being first assembled, and must be checked after the 1st 50 kilometres, 1st 100 kilometres, 1st 200 kilometres and every 1000 kilometres thereafter of driving. Failure to perform this check may result in a wheel coming loose from the trailer, causing a crash leading to death or serious injury. Refer to the Inspection, Service & Maintenance section for proper tightening sequence and torque value for the wheel nut bolts.

See Chart Below

WARNING

Wheel nuts are prone to loosen after being first assembled. Death or serious injury can result.

Check Wheel nuts for tightness on a new trailer, after re-mounting of a wheel at 1st 50km, 1st 100km, 1st 200km and every 1000km's thereafter of driving.

4 CHECKING THE TRAILER DURING & BEFORE EACH TOW

WHEEL NUT TORQUE & TIGHTENING PATTERN

- An impact / rattle gun if used, must only be used to “nip up” the wheel nuts (for speed) ·
- An impact gun should never be used to achieve the final wheel nut torque setting ·
- The correct nut torque sequence for the wheel must be used, to correctly and centrally locate the wheel on the hub of the trailer ·
- It is imperative that the final wheel nut torque must be achieved manually, using a properly calibrated, high quality torque wrench

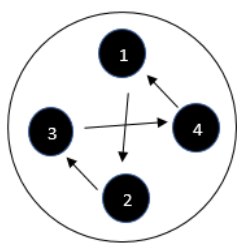

4 Lug Tightening Pattern

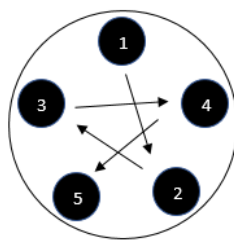

5 Lug Tightening Pattern

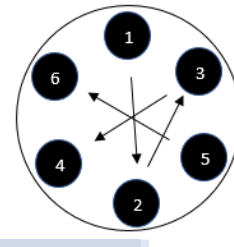

6 Lug Tightening Pattern

Torque Setting Guide		
Wheel Stud	Foot Pounds	Newton Metres
1/2" studs	100 ft-lbs	135Nm
5/8" Studs	175 ft-lbs	237Nm

**Most of our trailers have 1/2" stud so use 135 Nm torque.
4.5-ton trailers have 5/8 studs so use 237 Nm torque**

Important - Please Note:

- It is essential that wheel nuts should be re-torqued after an initial run-in period (pre-determined km's)
- We suggest the wheel nut tension should be re-checked after the 1st 50 km of operation

5 BREAKING-IN A NEW TRAILER

5.1 Adjust Brakes shoes

Brake shoes and drum experience a rapid initial wear. The brakes must be adjusted after the first 200 Kilometres of use, and each 4,000 kilometres thereafter. Most axles are fitted with brake shoes that must be manually adjusted. This must be done by an authorised dealer or mechanic or Modern Trailers.

If fitted with mechanical cable brakes this can be adjusted by Turing the turn buckle on the cable inwards.

5.2 Retighten Wheel nuts at 1st 50km

Wheel Nuts can sift and settle quickly after being first assembled, and must be checked after the 1st 50km, 1st 100km, 1st 200km and every 1000km's. failure to perform this check may result in a wheel coming loose from the trailer.

5.3 Tyre Pressure

Check tyre pressure on all wheels of the trailer. Inflate to the value indicated on the VIN plate located on the left-hand side of the draw bar.

5.4 Check Hubs

Check Hubs after 1000k kilometres for excessive heat. Also push the wheel in and out to see if there is movement in the hub, if so this would need to be adjusted. Overtightening or too lose in the hub can cause bearing damage. Service is required regularly. See service chart below.



MODERN TRAILERS

6 INSPECTION, SERVICE & MAINTANANCE

6.1 Inspection, Service & Maintenance Summary Charts

You must inspect, maintain and service you trailer regularly to insure reliable operation. Inspections can be performed by any person or persons but most service must be done by a authorised dealer or mechanic or by returning it to Modern Trailers.

Modern Trailers Inspection Service Intervals						
Item	Service Required	Manual Section Reference	Service Interval			
			Before Each Use	Every 3 Months	Every 6 Months	Every Year
U-Bolts	Checked by Dealer		•			•
Breakaway Brakes	Check Operation					
Breakaway Battery	Fully charge, connection clean		•			
Breakaway Switch	Test Operation & Connection		•			
Brakes, all types	Check Operation		•			
Brake Shoes	Check operation			First 200km	4000km	thereafter
Brake Cable	Adjust to each load		•			
Brakes Hydraulic	Check fluid level & replenish. Check for leaks/ sticking.			•		
Master Cylinder	inspect for cracks, leaks, kinks.			12 months		•
Brake Lines	Verify operation/inspect			12 months		•
Lights	Check for proper operation		•			
Trailer Body	Wash to remove road grime & grease			•		
Trailer Chassis	Inspect Chassis & draw bar for cracks					•
Welds	Inspect all welds, repair as needed				•	
Tyres						
	Check Tyre Pressure when cold		•			
	Rotate tyres				•	
	Inspect treads & side walls			•		
Wheel Bearings Hubs						
	Check for free running & lubricant			•		
	Running in hubs			First 1000	kilometres	
	Service check re-grease or replace					•
Override coupling	Re- grease with Hub service					•
Cable brake adjustment			•	Depends on the load		
Axle, Spring & coupling Bolts						
	Check for tension			•		
	Inspect for crakes in the U-bolts			•		

Section 6 - Inspection, Service & Maintenance

6.2 Bearing & Hub Service

Disassemble, inspect and re-pack the wheel bearings every 12 months or 10,000 Kilometres, whichever occurs first.

If a trailer wheel bearing is immersed in water, it must be repacked after each immersion

If your trailer has not been used for an extended amount of time, have the bearings inspected and packed more frequently, at least every six months and prior to use.

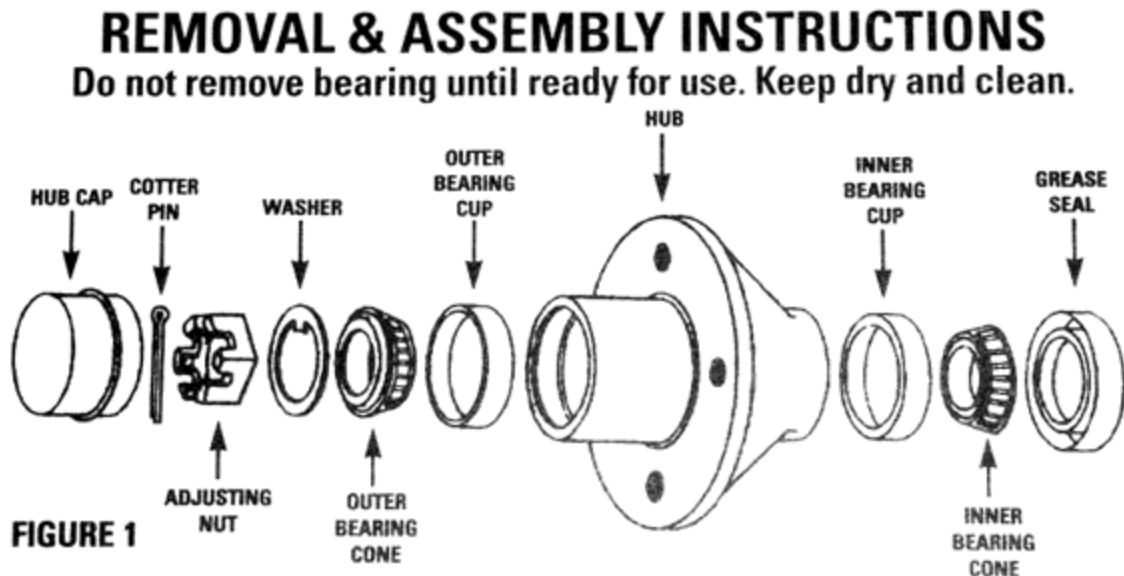

- After Removing the grease cap, split pin castle nut & washer, remove the hub by pulling on the hub to slide of the axle shaft. NOTE, the outer bearing cone will come out but the outer bearing cups on both sides will stay in the hub as they are pressed on.
- The cups would need to be removed by a qualified person or mechanic.
- Replace bearings that have flat spots on the rollers, broken roller cages, rust or pitting. Always replace the bearings and cups in a set. The inner & outer bearings are to be replaced at the same time.
- Replace seals that have nicks, tears or wears.
- *Lubricate the bearings with a high-quality EP-2 automotive wheel bearing grease.*

Every time the wheel hub is removed, and the bearings are reassembled, follow the steps below to check the wheel bearings for free running and adjust.

- Turn the hub slowly, by hand while tightening the castle nut, until you can no longer turn the hub by hand.
- Loosen the castle nut just until you can turn it (*the castle nut*) by hand. Do not turn the hub while castle nut is loose.
- Put a new cotter pin through the castle nut and axle.
- Check the adjustments. Both the hub and the castle nut should be able to move freely (*the castle nut motion will be limited by the Split pin*).

7 TECHINCAL REFERNCE

7.1 TRAILER LIGHTING ELECTRICAL CONNECTION

The electrical wiring on your Modern Trailer has been designed and built in accordance with the Australian Standards ADR that were in affect when the trailer was produced.

LEFT SIDE

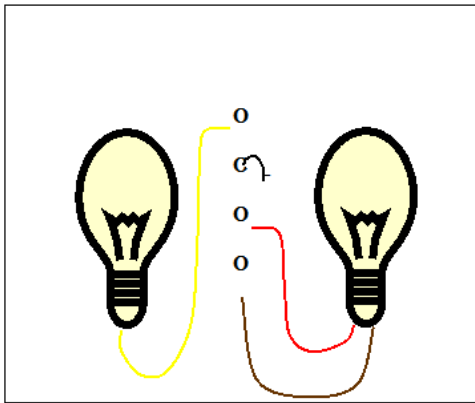

YELLOW
WHITE
RED
BROWN

RIGHT SIDE

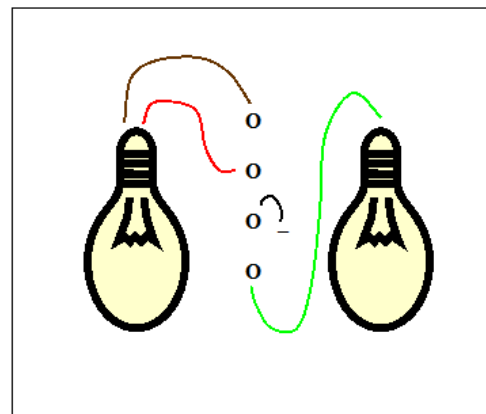

BROWN
RED
WHITE
GREEN

7 Pin Large Round Plug and Socket

PIN No.	CIRCUIT	COLOUR
1	Left-hand turn	Yellow
2	Reversing signal	Black
3	Earth return	White
4	Right-hand turn	Green
5	Service brakes	Blue
6	Stop lamps	Red
7	Rear lamps, clearance & side marker lamps	Brown





*Cable entry view

MODERN TRAILER

7 Pin Flat Plug and Socket

PIN No.	CIRCUIT	COLOUR
1	Left-hand turn	Yellow
2	Reversing signal	Black
3	Earth return	White
4	Right-hand turn	Green
5	Service brakes	Blue
6	Stop lamps	Red
7	Rear lamps, clearance & side marker lamps	Brown

*Cable entry view

SECTION 7 - TECHNICAL REFERENCE

7.2 Axle sizes & Bearing Numbers

- 39mm Round Axle - Standard Holden Bearing LM
- 40mm Square Axle - Standard Holden Bearing LM
- 45mm Square Axle - Slimline or Parallel Bearings
- 50mm Square Axle - Slimline or Parallel Bearings

LM Bearing Sets

	PART NUMBER	HOUSING DIAMETER NOMINAL	BEARING JOURNAL/SEAL JOURNAL DIAMETER NOMINAL
Inner Bearing	LM67048/10 (Holden Inner)	59.10 mm	31.75mm
Outer bearing	LM11949/10 (Holden outer)	45.20 mm	19.05mm
Grease seal	28550	59.10 mm	37.5mm
Grease cap		45.20 mm	N/A

Slimline Bearing Sets

	PART NUMBER	HOUSING DIAMETER NOMINAL	BEARING JOURNAL/SEAL JOURNAL DIAMETER NOMINAL
Inner bearing	L68149/10 (Ford inner)	59.10 mm	35.00mm
Outer Bearing	LM12749/10 (Ford outer)	45.20 mm	22.00mm
Grease seal		59.10 mm	43.9mm
Grease cap		45.20 mm	N/A

Parallel Bearing Sets

	PART NUMBER	HOUSING DIAMETER NOMINAL	BEARING JOURNAL/SEAL JOURNAL DIAMETER NOMINAL
Inner Bearing	L68149/10	59.10 mm	35.00mm
Outer Bearing	L68149/10	59.10 mm	35.00mm
Grease seal		59.10 mm	43.9mm
Grease cap		63.00mm	N/A

SECTION 7 - TECHNICAL REFERENCE

7.3 Springs

Modern Trailers uses a variety of springs depending on the type of trailer & load required, the most common springs used are:

7.4 Slipper Springs

You must inspect the rear spring shackle for wear over time as the spring slides back and forth it will cut into the rear spring shackle, if worn it must be replaced. (*Figure 2*)

Check the front spring shackle for wear in the bolt hole (*Figure 1*)

- 3-Leaf 600kg Rating
- 4-Leaf 750kg Rating
- 5-leaf 900kg Rating
- 7-leaf 1400kg Rating
- 9-Leaf 1500kg Rating



7.5 Parts required for spring fittings are:

1. Front Spring Hanger (*Figure 1*)
2. Rear Spring Hanger (*Figure 2*)
3. Bolt 12mm x 80mm Hi-Tensile (*Figure 3*)
4. Nut Nylock 12mm (*Figure 4*)



Figure 1



Figure 2



Figure 3

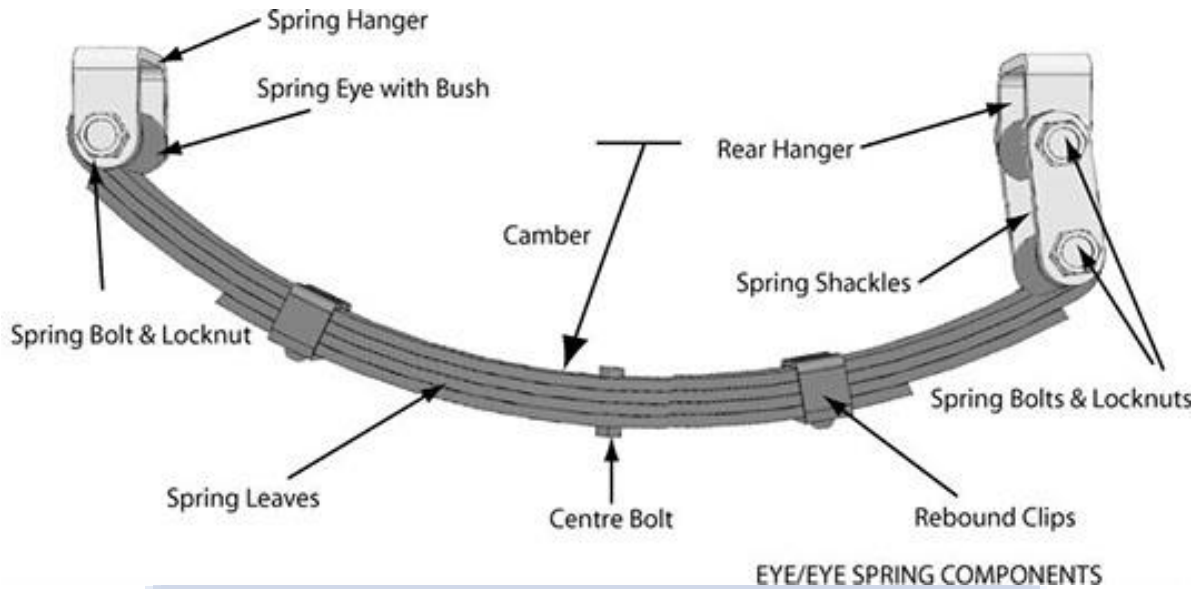

Figure 4

SECTION 7 - TECHNICAL REFERENCE

7.6 Shackle Springs (Figure 1)

Shackle Springs are more commonly used on our Galvanized Trailers



(Figure 1)

7.6 Off Road Shackle Springs (Figure 2)

Off road springs are used on off road trailers.



(Figure 2)

SECTION 7 - TECHNICAL REFERENCE

7.7 Rocker Roller Springs

Rocker Roller springs are a load sharing suspension and are used standard on our galvanized trailers, Commercial Trailer, Industrial trailers, Tray top Trailers and all trailers that have a rating over 2000kg.

Rocker springs have wearing parts Roller bush that must be checked for wear, also Grease regularly on the grease nipple points in the centre rocker arm and roller bushes.



7.8 Parts required for mounting axles to the springs are:

There are different size U-bolts & Fish plates depending on the axle size as stated in section 7.2.

1. Axle Pads (*Figure 1*)
2. Fish Plates (*Figure 2*)
3. U-Bolts (*Figure 3*)
4. Nut Nylocks (*Figure 4*)



Figure 1



Figure 2



Figure 3-4

8 - Structural Warranty

Congratulations on purchasing your new Modern Trailer

1. All our new trailers are covered by a structural Warranty.
 2. The Warranty entitles the original purchaser from the date of purchase and covers the chassis and drawbar only from fatigue and has a guarantee for a period of one (5 years) sixty months for domestic use (1 year) twelve months for business, commercial or industrial use from original date of purchase subject to the terms below:
 3. Modern Trailers retains the right to repair or replace any part which in the opinion of the manufacturer is defective due to faulty material or workmanship provided that the trailer has been operated in accordance with the manufacturer's instructions and safe towing practices:
 4. Modern Trailers Warranty does not cover any trailer parts or accessories that are not manufactured by Modern Trailers. All 3rd party parts or accessories are supplied with the Warranty terms & conditions and period provided by the manufacturer of any such parts or accessories. Those accessories include but are not limited to:
 - Jockey Wheels, Jacks, Legs and Winches etc
 - Axles, brakes, callipers, lights and plugs
 5. All Warranty repairs must be performed during normal business hours at our Modern Trailers, Factory 12 Sherriffs road Lonsdale 5160. Or 1 levels court Pooraka SA 5095
- Warranty repairs carried out in other locations require prior authorisation From Modern Trailers. Unauthorised repairs are not covered under this Warranty.**
6. The purchaser is responsible to care for their Trailer in accordance with the 'Modern Trailers Maintenance manual'.
 7. The purchaser will be responsible for paying all service call fees or transport charges, and damages and loss incurred in connection with the transportation of the trailer to and from Modern Trailers premises.
 8. The following is not covered by Warranty in any way what so ever:
 - Paint
 - Rust
 - Wheels & Tyres-
 - General consumables e.g. Springs, bearings, brakes, wiring etc.
 - Any other items deemed to be consumable
 9. This Warranty does not apply to any trailer which has been:
 - a) subject to misuse, neglect, accident or alteration by any person.
 - b) damaged or destroyed by fire, flood, Act of God or other inevitable accident.
 - c) hired to any person or persons.This Warranty is in addition to any rights or remedies the purchaser has under the Trades Practices Act or state laws.
 10. This Warranty is not offered on products sold at auction or as a demonstrator, factory seconds or on used products, unless with express written permission by Modern Trailers.
 11. Unless any addition or attachment to this product has Modern Trailers, specific approval or is sold as a Modern Trailers product the Warranty on the trailer is waived. Trailers are designed to perform a specific task under established test loads and unauthorised attachments may produce stresses for which the design is not appropriate.
 12. Design, specifications and colours are subject to change without notice.
 13. Modern Trailers Structural Warranty may change at any time without notice.

9 MAINTANANCE & SERVICE SCHEDULE

1 Months

Check

- Wheels and bearings
- Spring Nuts for tension
- Axle Nuts for tension
- Coupling Nuts for tension
- Brake cable adjustment
- Tire pressure
- Wheel Nuts

Replace or Repair

-
-
-
-

Date:.....

Signature:.....

3 Months

Check

- Wheels and bearings
- Spring Nuts for tension
- Axle Nuts for tension
- Coupling Nuts for tension
- Brake cable adjustment
- Brake Shoes
- Inspect U-bolts for cracks
- Tire pressure
- Wheel Nuts

Replace or Repair

-
-
-
-
-

Date:.....

Signature:.....

SECTION 9 - MAINTANANCE & SERVICE SCHEDULE

12 Months

Check

- Wheels and bearings
- Wheel Bearings
- Spring Nuts for tension
- Axle Nuts for tension
- Coupling Nuts for tension
- Brake cable adjustment
- Brake Shoes
- Inspect U-bolts for cracks
- Tire pressure
- Wheel Nuts
- Inspect trailer for any cracks
- Inspect all welds
- Wash & remove all road grime

Replace or Repair

.....

.....

.....

.....

.....

.....

.....

.....

.....

.....

Date:.....

Signature:.....

18 Months

Check

- Wheels and bearings
- Spring Nuts for tension
- Axle Nuts for tension
- Coupling Nuts for tension
- Brake cable adjustment
- Brake Shoes
- Inspect U-bolts for cracks
- Tire pressure
- Wheel Nuts

Replace or Repair

.....

.....

.....

.....

.....

.....

Date:.....

Signature:.....

SECTION 9 - MAINTANANCE & SERVICE SCHEDULE

24 Months

Check

- Wheels and bearings
- Wheel Bearings
- Spring Nuts for tension
- Axle Nuts for tension
- Coupling Nuts for tension
- Brake cable adjustment
- Brake Shoes
- Inspect U-bolts for cracks
- Tire pressure
- Wheel Nuts
- Inspect trailer for any cracks
- Inspect all welds
- Wash & remove all road grime

Replace or Repair

-
-
-
-
-
-
-

Date:.....

Signature:.....

30 Months

Check

- Wheels and bearings
- Spring Nuts for tension
- Axle Nuts for tension
- Coupling Nuts for tension
- Brake cable adjustment
- Brake Shoes
- Inspect U-bolts for cracks
- Tire pressure
- Wheel Nuts

Replace or Repair

-
-
-
-
-

Date:.....

Signature:.....

SECTION 9 - MAINTANANCE & SERVICE SCHEDULE

36 Months

Check

- Wheels and bearings
- Wheel Bearings
- Spring Nuts for tension
- Axle Nuts for tension
- Coupling Nuts for tension
- Brake cable adjustment
- Brake Shoes
- Inspect U-bolts for cracks
- Tire pressure
- Wheel Nuts
- Inspect trailer for any cracks
- Inspect all welds
- Wash & remove all road grime

Replace or Repair

.....

.....

.....

.....

.....

.....

.....

.....

.....

Date:.....

Signature:.....

42 Months

Check

- Wheels and bearings
- Spring Nuts for tension
- Axle Nuts for tension
- Coupling Nuts for tension
- Brake cable adjustment
- Brake Shoes
- Inspect U-bolts for cracks
- Tire pressure
- Wheel Nuts

Replace or Repair

.....

.....

.....

.....

.....

Date:.....

Signature:.....

SECTION 9 - MAINTANANCE & SERVICE SCHEDULE

48 Months

Check

- Wheels and bearings
- Wheel Bearings
- Spring Nuts for tension
- Axle Nuts for tension
- Coupling Nuts for tension
- Brake cable adjustment
- Brake Shoes
- Inspect U-bolts for cracks
- Tire pressure
- Wheel Nuts
- Inspect trailer for any cracks
- Inspect all welds
- Wash & remove all road grime

Replace or Repair

-
-
-
-
-
-
-

Date:.....

Signature:.....

54 Months

Check

- Wheels and bearings
- Spring Nuts for tension
- Axle Nuts for tension
- Coupling Nuts for tension
- Brake cable adjustment
- Brake Shoes
- Inspect U-bolts for cracks
- Tire pressure
- Wheel Nuts

Replace or Repair

-
-
-
-
-

Date:.....

Signature:.....

SECTION 9 - MAINTANANCE & SERVICE SCHEDULE

60 Months

Check

- Wheels and bearings
- Wheel Bearings
- Spring Nuts for tension
- Axle Nuts for tension
- Coupling Nuts for tension
- Brake cable adjustment
- Brake Shoes
- Inspect U-bolts for cracks
- Tire pressure
- Wheel Nuts
- Inspect trailer for any cracks
- Inspect all welds
- Wash & remove all road grime

Replace or Repair

.....

.....

.....

.....

.....

.....

.....

.....

.....

.....

Date:.....

Signature:.....

66 Months

Check

- Wheels and bearings
- Spring Nuts for tension
- Axle Nuts for tension
- Coupling Nuts for tension
- Brake cable adjustment
- Brake Shoes
- Inspect U-bolts for cracks
- Tire pressure
- Wheel Nuts

Replace or Repair

.....

.....

.....

.....

.....

.....

Date:.....

Signature:.....

SECTION 9 - MAINTANANCE & SERVICE SCHEDULE

72 Months

Check

- Wheels and bearings
- Wheel Bearings
- Spring Nuts for tension
- Axle Nuts for tension
- Coupling Nuts for tension
- Brake cable adjustment
- Brake Shoes
- Inspect U-bolts for cracks
- Tire pressure
- Wheel Nuts
- Inspect trailer for any cracks
- Inspect all welds
- Wash & remove all road grime

Replace or Repair

.....

.....

.....

.....

.....

.....

.....

.....

.....

Date:.....

Signature:.....

78 Months

Check

- Wheels and bearings
- Spring Nuts for tension
- Axle Nuts for tension
- Coupling Nuts for tension
- Brake cable adjustment
- Brake Shoes
- Inspect U-bolts for cracks
- Tire pressure
- Wheel Nuts

Replace or Repair

.....

.....

.....

.....

.....

Date:.....

Signature:.....

SECTION 9 - MAINTANANCE & SERVICE SCHEDULE

84 Months

Check

- Wheels and bearings
- Wheel Bearings
- Spring Nuts for tension
- Axle Nuts for tension
- Coupling Nuts for tension
- Brake cable adjustment
- Brake Shoes
- Inspect U-bolts for cracks
- Tire pressure
- Wheel Nuts
- Inspect trailer for any cracks
- Inspect all welds
- Wash & remove all road grime

Replace or Repair

.....

.....

.....

.....

.....

.....

.....

.....

.....

.....

Date:.....

Signature:.....

90 Months

Check

- Wheels and bearings
- Spring Nuts for tension
- Axle Nuts for tension
- Coupling Nuts for tension
- Brake cable adjustment
- Brake Shoes
- Inspect U-bolts for cracks
- Tire pressure
- Wheel Nuts

Replace or Repair

.....

.....

.....

.....

.....

.....

Date:.....

Signature:.....

SECTION 9 - MAINTANANCE & SERVICE SCHEDULE

96 Months

Check

- Wheels and bearings
- Wheel Bearings
- Spring Nuts for tension
- Axle Nuts for tension
- Coupling Nuts for tension
- Brake cable adjustment
- Brake Shoes
- Inspect U-bolts for cracks
- Tire pressure
- Wheel Nuts
- Inspect trailer for any cracks
- Inspect all welds
- Wash & remove all road grime

Replace or Repair

-
-
-
-
-
-
-

Date:.....

Signature:.....

MODERN TRAILERS



Modern Trailers pty ltd

Factory/ Sales 12 Sherriffs Road West, Lonsdale SA 5160

Phone: 08 8326 5041

Sales: 1 Levels Court, Pooraka SA 5095

Phone: 08 8262 2562

www.moderntrailers.com.au